

FRONT + REAR ELEVATION

1:100

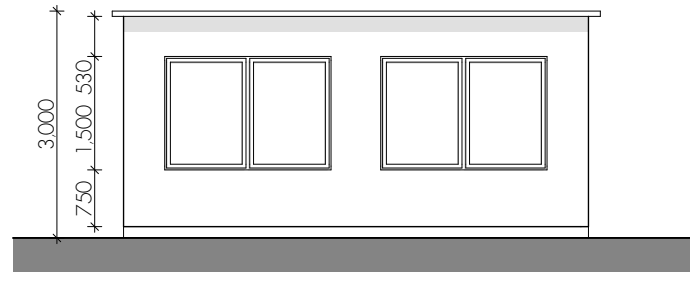

SIDE ELEVATION

1:100

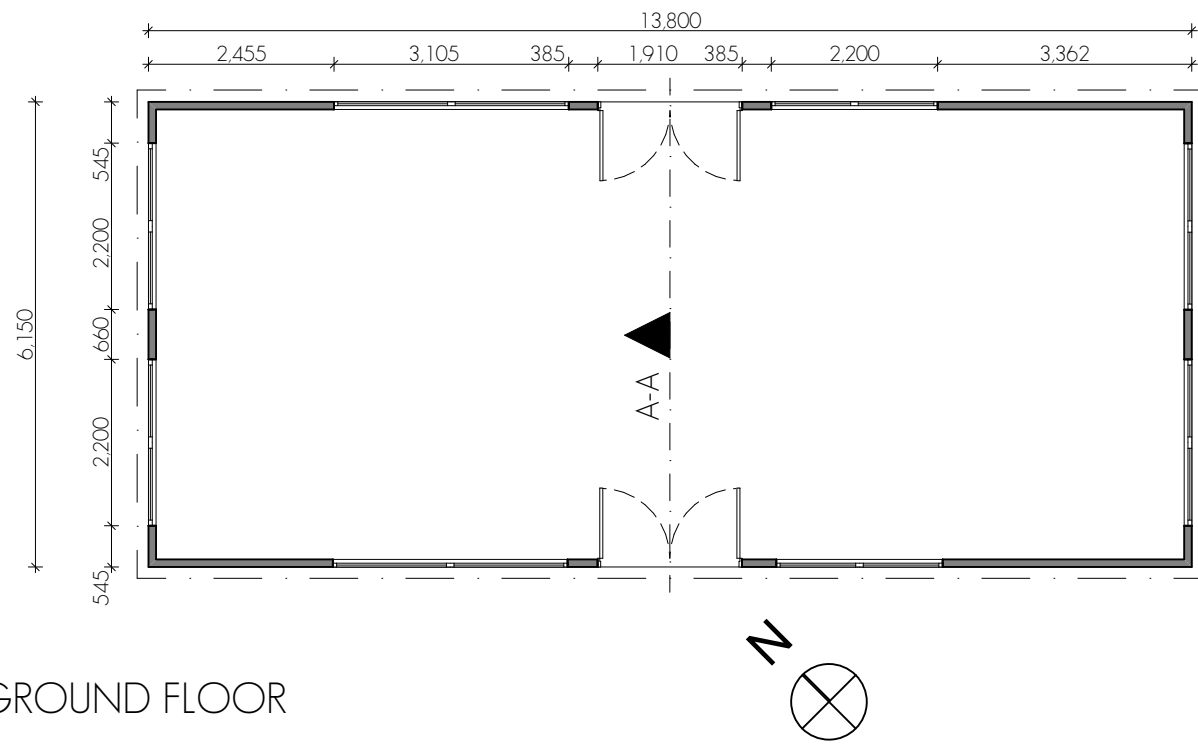

GROUND FLOOR

1:100

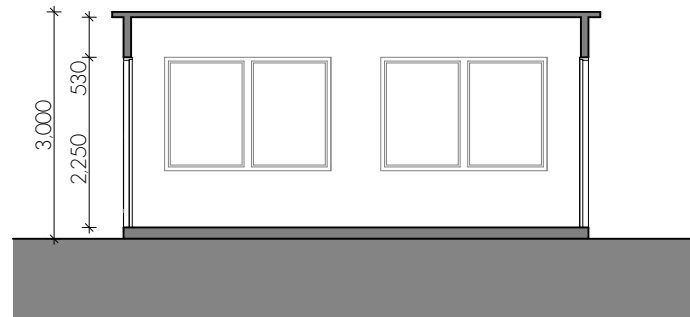

SECTION A-A

1:100

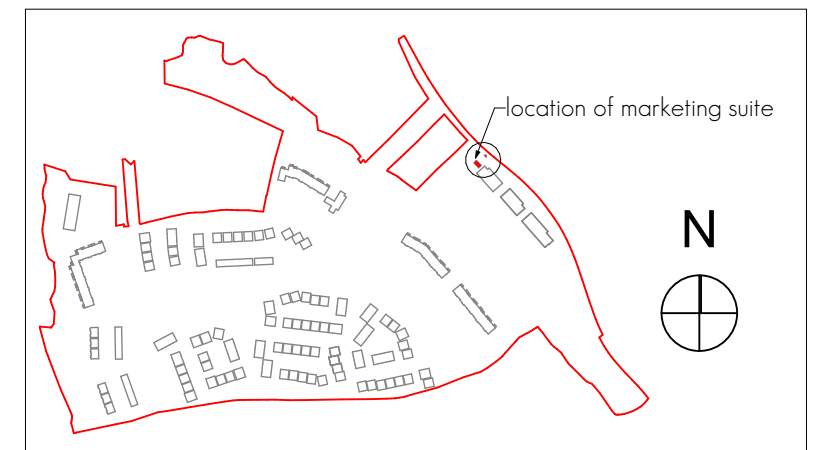

KEY PLAN

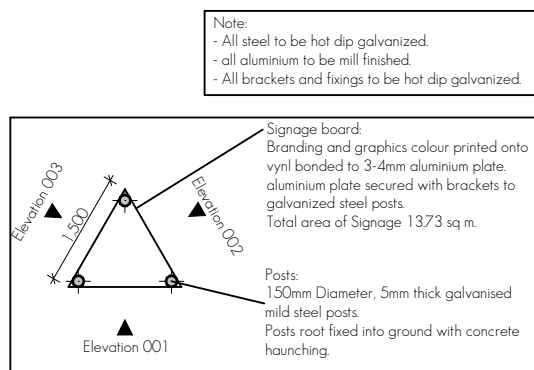

GROUND FLOOR PLAN

1:100

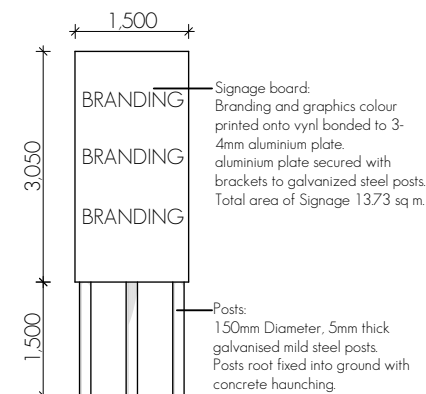

Elevation 001

1:100

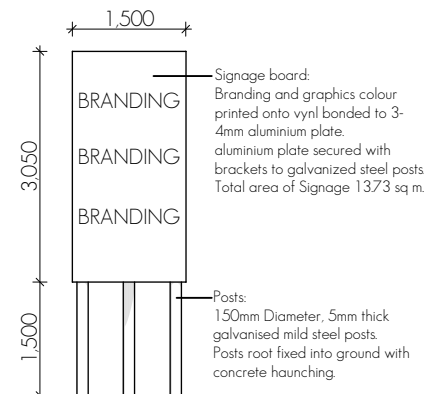

Elevation 002

1:100

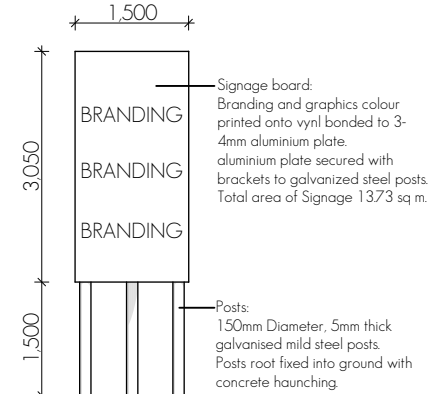

Elevation 003

1:100

Issued for Planning		GOS MD 12/04/2019 A	
Issue Description	dm	ckd	date
Client: CAIRN HOMES PROPERTIES LTD.			
Project: RESIDENTIAL DEVELOPMENT			
Site: CASTLETREASURE, DOUGLAS, CO. CORK			
Title: MARKETING SUITE			
Project Architect: MARK DIGNAM			
A3 Sheet Scale: 1:100			
Project No: 18205-PLA-020			
Issue: A			

Meitheal  
design partners  
Architects